



SHEET NO. **S404**

REVISIONS  
11/28/07  
V8/08

JOB NO. 40567  
DATE 11/28/07  
DRAWN BY DT  
CHECKED BY MAG

**GBC DESIGN, INC.**  
8378 W. Market St. Akron, OH 44388-8806  
Phone 380-886-0226 Fax 380-886-6782

**SAAD DEVELOPMENT CORPORATION**  
3601 SPRING HILL BUSINESS PARK, SUITE 200  
MOBILE, AL 36608  
PHONE: 251-478-7223  
FAX: 251-478-7223

**SAAD DEVELOPMENT CORPORATION**  
2007 SAAD DEVELOPMENT CORPORATION  
ALL RIGHTS RESERVED. NO PART OF THIS DOCUMENT OR ANY INFORMATION CONTAINED HEREIN IS TO BE REPRODUCED OR TRANSMITTED IN ANY FORM OR BY ANY MEANS, ELECTRONIC OR MECHANICAL, INCLUDING PHOTOCOPYING, RECORDING, OR BY ANY INFORMATION STORAGE AND RETRIEVAL SYSTEM.

**FEDEX GROUND STATESBORO, GA.  
PACKAGE DISTRIBUTION CENTER  
3400 ZELL MILLER PARKWAY  
STATESBORO, GA. 30458**

SECTIONS AND DETAILS

SHEET NO. **S404**

AB-1B ANCHOR BOLT SCHEDULE		
DIA	EMBEDMENT	"L"
3/4"	1-5"	1-11 1/2"
7/8"	1-7"	2-1 1/2"
1"	1-10"	2-4 1/2"
1 1/8"	2-1"	2-7 1/2"
1 1/4"	2-3"	2-4 1/2"
1 1/2"	2-5"	3-2 1/2"
1 3/4"	3-2"	3-5 1/2"
2"	3-7"	4-1 1/2"

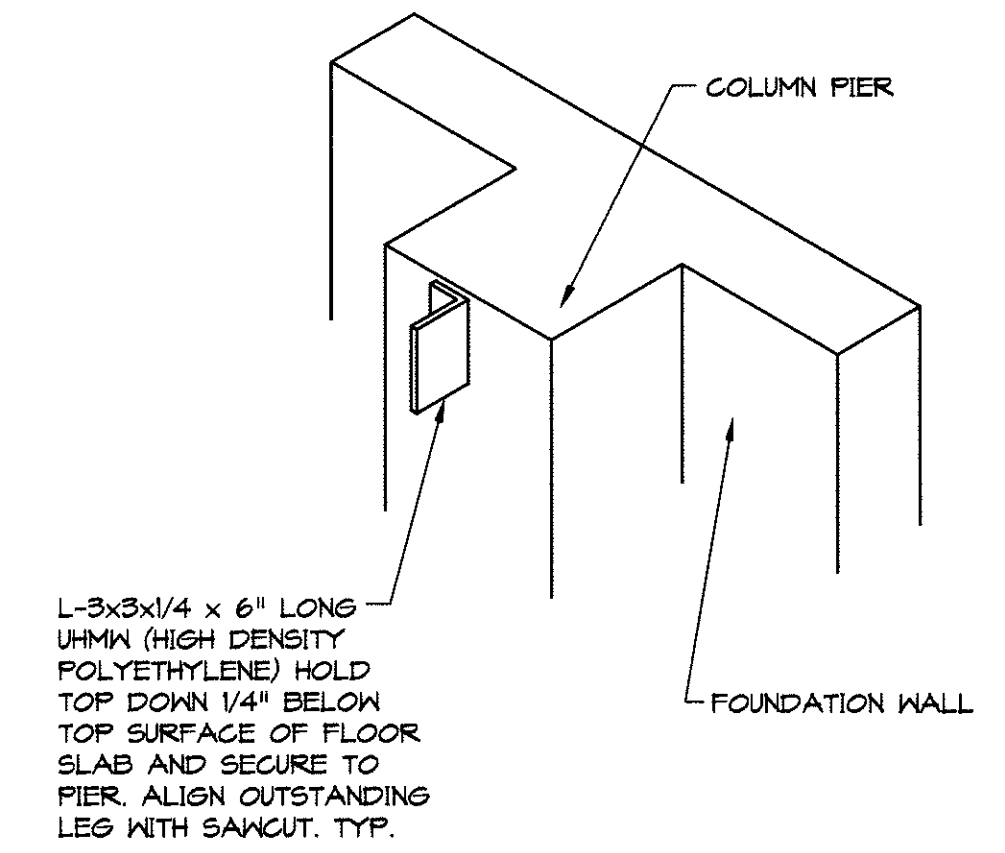
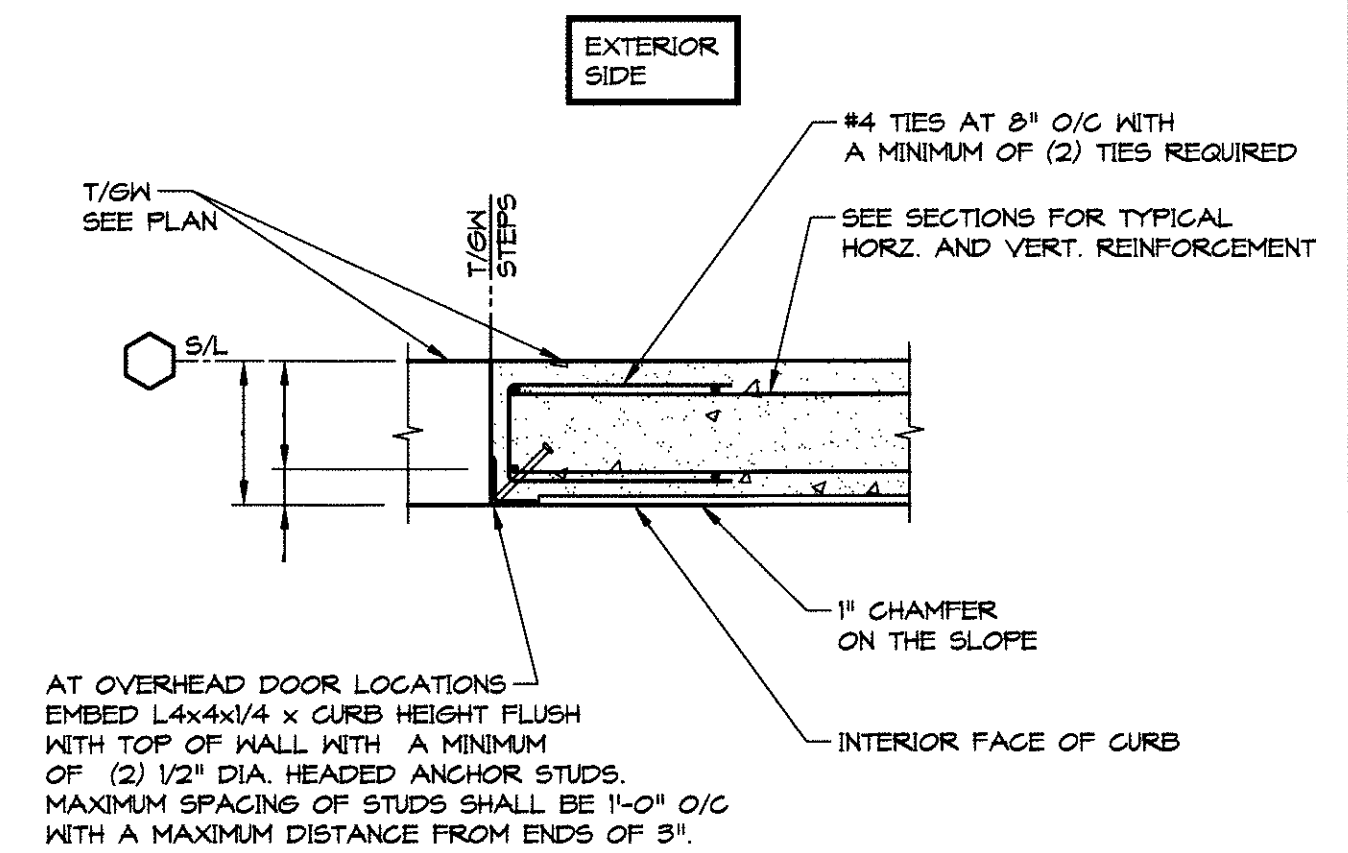
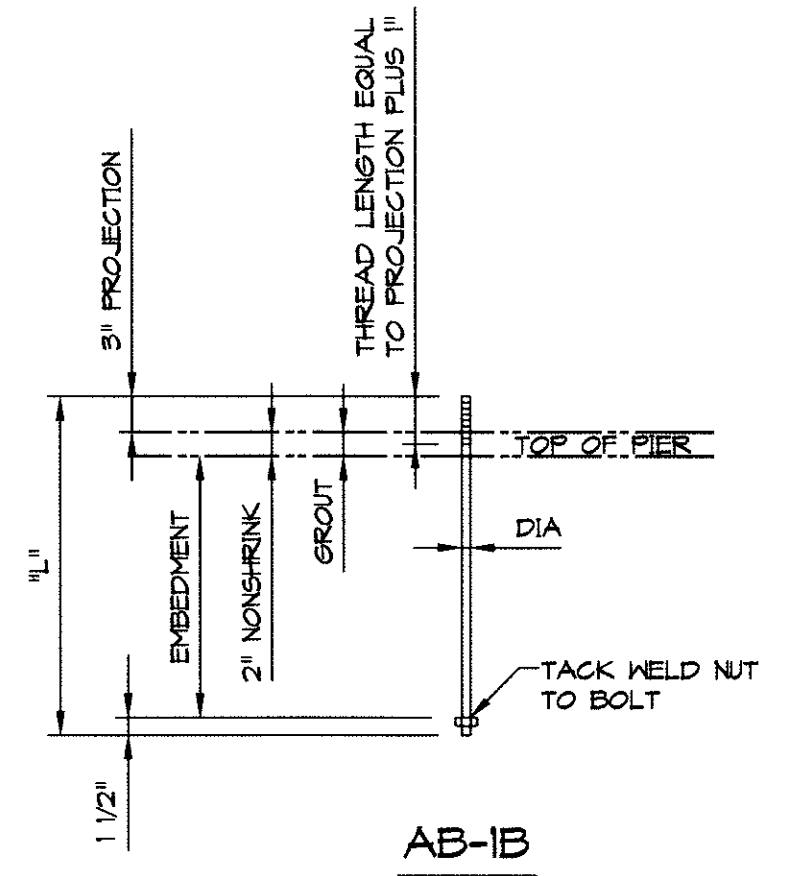

**1** ANCHOR ROD 2

**2** TYP GRADE WALL CONST @ CURB ENDS

**3** TRENCH DRAIN & COL PIERS MEET SAWCUT

**4**

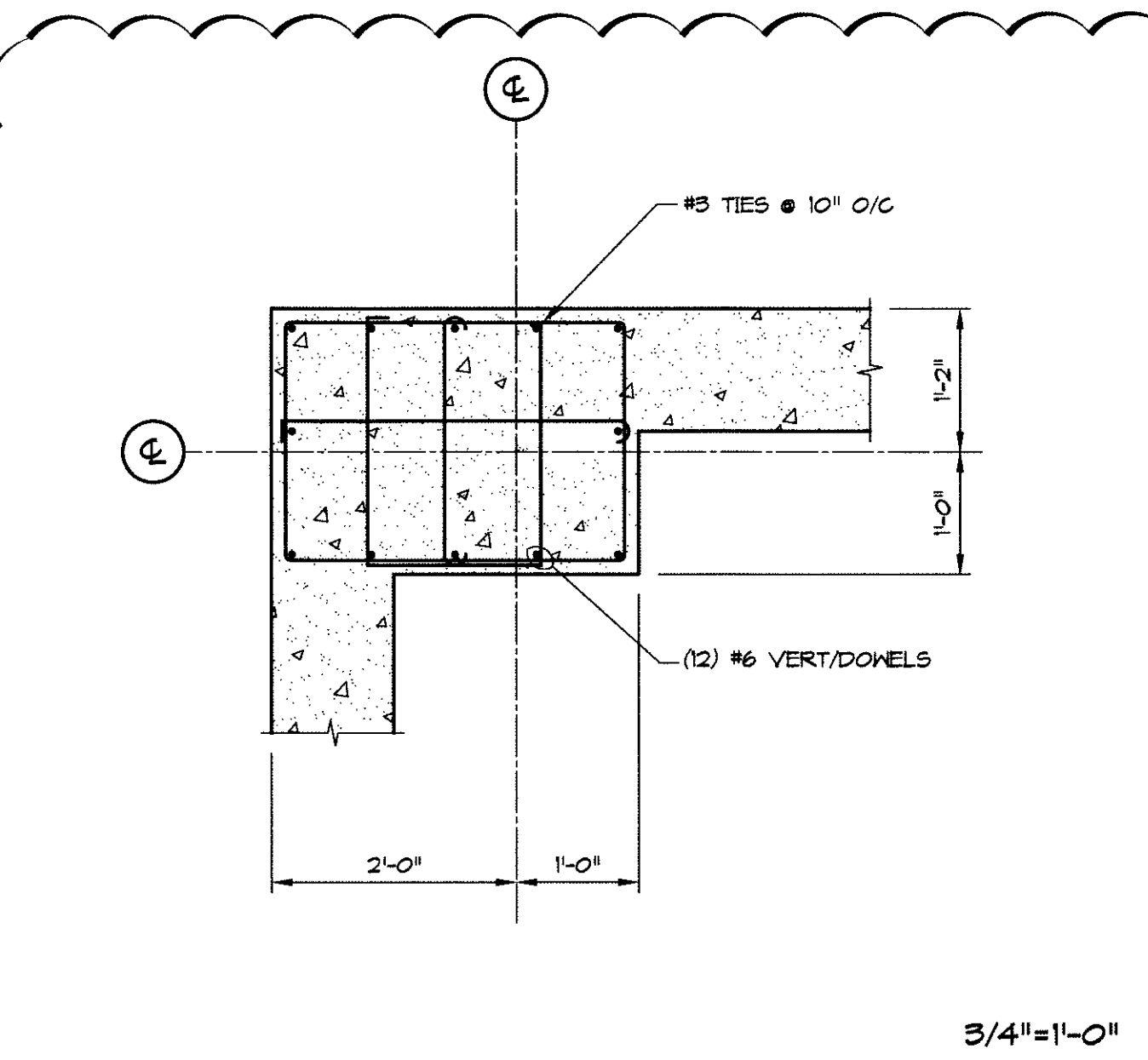

**5** PIER P5

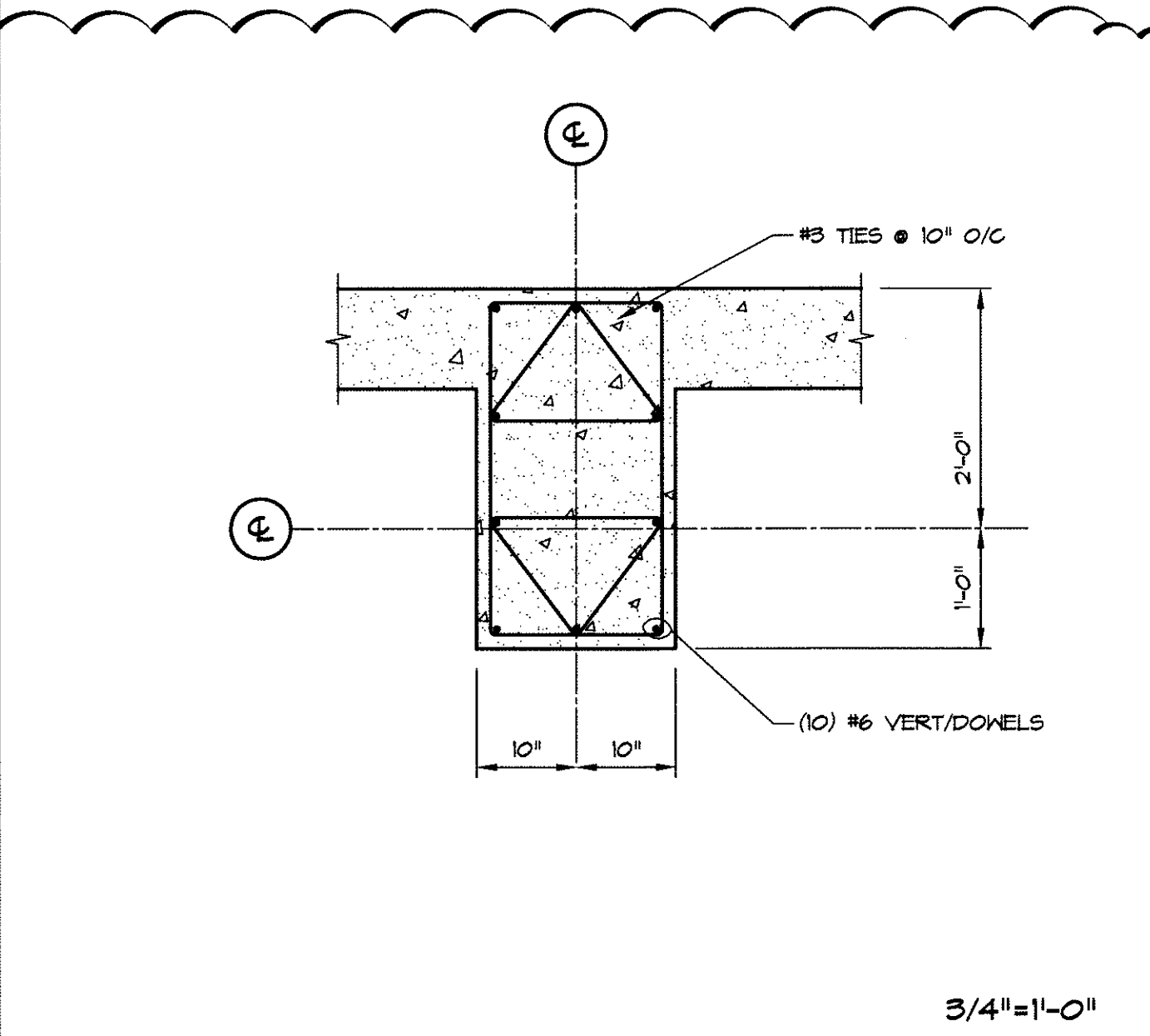

**6** PIER P6



**7**



**8**



**9**



**10**



**11**

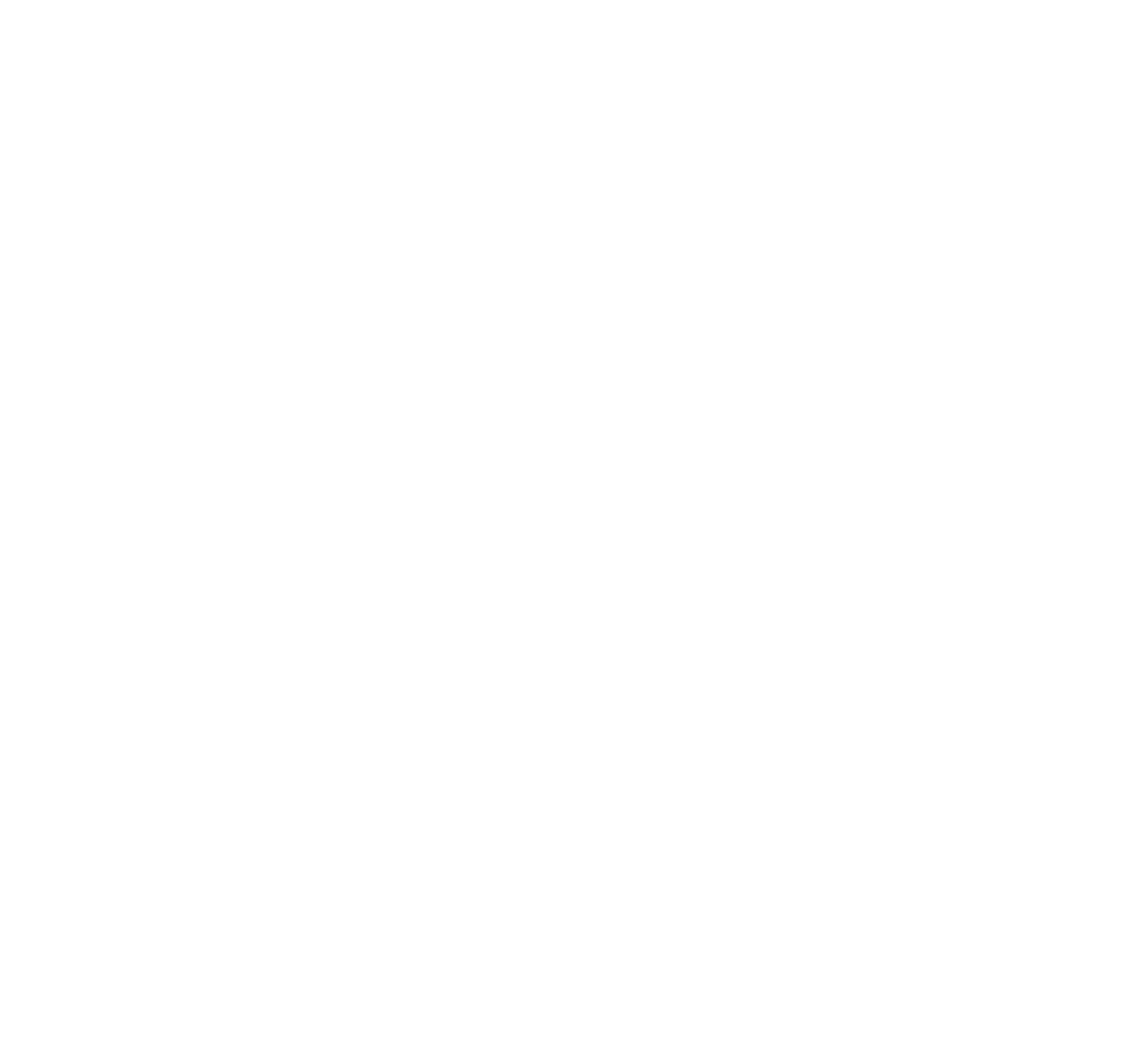

**12**



**Browning Engineers Inc.**  
Structural Design Group  
2701 LATROBE DRIVE, SUITE 100  
DANVILLE, NORTH CAROLINA 27033  
(704) 752-1111